

Multifeeder Technology™  
**MFT350™**  
Series of Friction Feeders



*The Leader in High Performance,  
High Speed Friction Feeding  
Equipment and Accessories*

**MFT 350™ Typical Applications**

- Copy Paper
- Stationery
- Signatures
- Resume Paper
- Envelopes
- And many more...

**A Hardworking, Multifunctional  
Friction Feeder**

For all of your feeding needs, Multifeeder Technology™ has a solution for you. The MFT series of friction feeders is designed to handle a wide variety of products, with minimal changeover and set up. Whether you are individually feeding compact discs or batch counting 100 sheets of paper, we have a system to meet your specific requirements.

All Multifeeder Technology friction feeders include double detection, mis-feed detection and batch counting as standard features, rather than costly extras. With an MFT friction feeder, everything you need is right at your fingertips.

**Maximize  
Productivity**

A few minor adjustments allow you to make product changeovers in minutes, saving you valuable time and resources. The specially-designed sealed membrane keypad contains easy access “Hot Keys” for the most frequently used control adjustments. Standard features like these make Multifeeder Technology friction feeders extremely user friendly and help maximize your uptime.

**Superior Technology**

All MFT friction feeders are powered by a high speed, brushless servo motor with

encoder feedback, while infrared sensors are used to visually inspect your product as it's being fed. An on-board computer monitors and controls the entire process, providing accurate speed, product count, feeding jam/empty control and multiple product detection.

Our innovative feeding mechanism ensures your product's integrity remains intact by gently separating product from the bottom of an inclined stack, regardless of the material consistency or thickness.

If you're looking for a simple solution to feeding a product quickly, reliably and accurately, look no further than Multifeeder Technology.

**Multifeeder**  
TECHNOLOGY

# MFT350™ Series of Friction Feeders

The Leader in High Performance, High Speed Friction Feeding Equipment and Accessories

## MFT 350™ Standard Features

- Portable Unit:** Self-contained unit with only one electrical enclosure
- Computer Controlled:** Computer control provides thousands of control calculations per second for precise start, stop, watch dog and multiple product detection
- Easy Interface:** Standard signals available for easy interface with existing computer, PLC or other host machinery
- Production Log:** Automatically stores your production history in the feeder's computer with production count, and fault logging with time, date and type of fault
- Intuitive User Interface:** Custom 22-key sealed membrane key pad with 2 x 40 character LCD display
- User Friendly Changeover:** Easy and accurate changeover with twist lock handles
- Ruggedly Built:** Hardened stainless steel shafts and sealed bearings for maximum life and 24-hour a day operation
- Quick Belt Replacement:** Three piece shaft assemblies for quick maintenance
- Three-Color Signal Light:** Green = ready Yellow = low product Red = fault
- Pre-select Counter:** Standard pre-select product count (1-999 per cycle)
- Optically Isolated Signals:** All interface signals isolated for accuracy
- Built for Harsh Environment:** Stainless steel shafts, sealed bearings, surface treated aluminum construction and sealed cast aluminum enclosures to protect internal parts
- One Year Warranty:** One year warranty on parts and labor

## MFT 350™ Specifications

- Minimum Product Size:** 25mm(W) x 25mm(L) [1" x 1"]
- Maximum Product Size:** 300mm(W) x 400mm(L) [12" x 16"]
- Minimum Product Thickness:** 0.05mm [0.002"]
- Maximum Product Thickness:** 8mm [0.3"]
- Maximum Belt Speed:** 211,000 mm/min [8300 in/min]
- Operating Temperature:** 10-35° C [50-90° F]
- Power Requirements:** 110 (230) volts 50-60 HZ maximum 6 amps
- Total Unit Weight:** 32 kg [70 lbs]
- Product Magazine:** 380mm [15"]
- Feeder Discharge:** Three standard lengths

We configure your machine for maximum performance.

## MFT 350™ Options

- |                          |                 |
|--------------------------|-----------------|
| Automatic Product Loader | Portable Stand  |
| Automatic Drop Table     | Catch Tray      |
| Remote Key Pad           | Barcode Scanner |
| Static Reduction System  | Deskjet Printer |
| Tall Product Magazine    |                 |

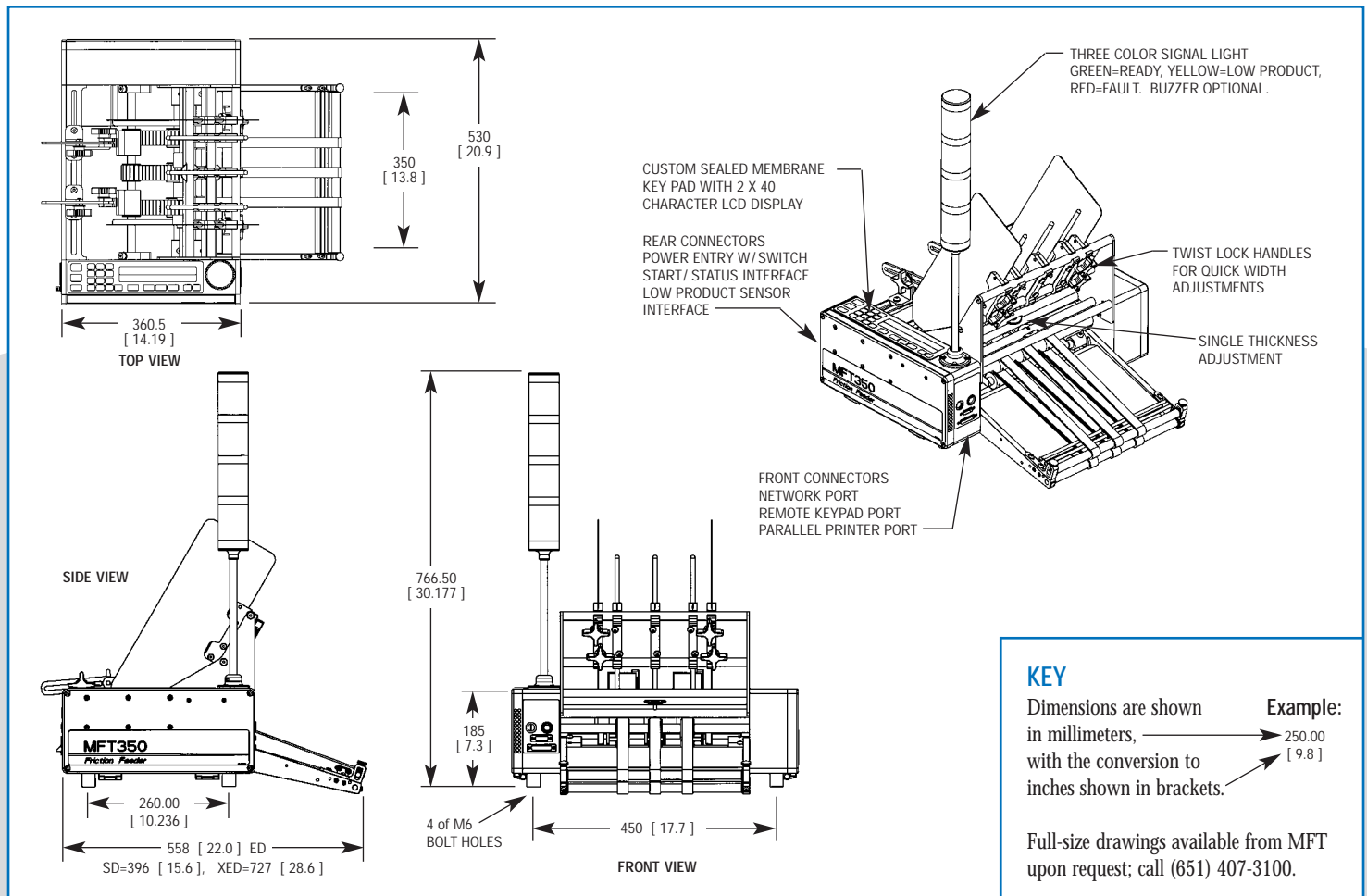

Multifeeder Technology,™ Inc.  
4821 White Bear Parkway  
White Bear Lake, MN 55110

Phone: 651-407-3100  
Fax: 651-407-3199

E-mail: sales@multifeeder.com  
Website: www.multifeeder.com