

## The SMCT Family of Catch Trays

The SMCT Family of Side Mounted Catch Trays from Multifeeder Technology® Inc. are ideal for batch counting small stacks of products such as greeting cards, envelopes, tags, and even bandages. The SMCT Side Mounted Catch Tray mounts directly to the discharge of your MFT Friction Feeder and can be used in stand-alone application, or integrated with any lug conveyor.

The SMCT Side Mounted Catch Trays with built in product guiding are ideal for controlling the feeding process at high speeds. Once the products are settled into the Catch Tray they're ready to be picked up by the conveyor lug with no delay. As soon as the product stack leaves the Catch Tray a sensor will signal the feeder to feed a new batch of products.

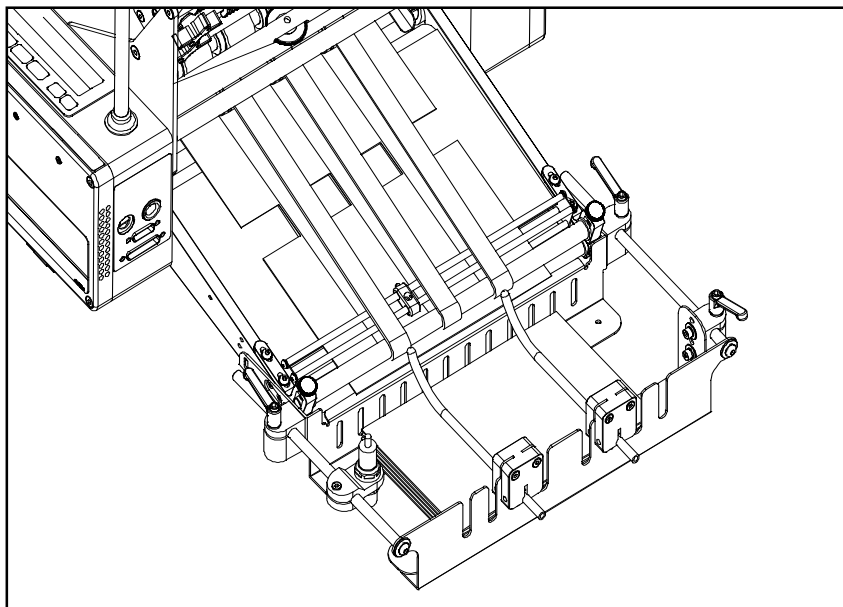

Fig. 1. SMCT 350 M Catch Tray on MFT 350 ED Friction Feeder

The SMCT Family of Side Mounted Catch Trays is available for all MFT Friction Feeder models. They provide a very cost effective, reliable packaging solution whenever integrated into fluted conveyors. The Multifeeder Technology® Portable Stand on Rollers makes it even more versatile. Roll the MFT Friction Feeder up to the side of the packaging line and use the hand crank to adjust the Catch Tray to its proper height for lug pick-off. With a photo sensor already mounted to the SMCT Catch Tray there is no need for integration.

This roll-away package can also be used as a stand alone off line counter.

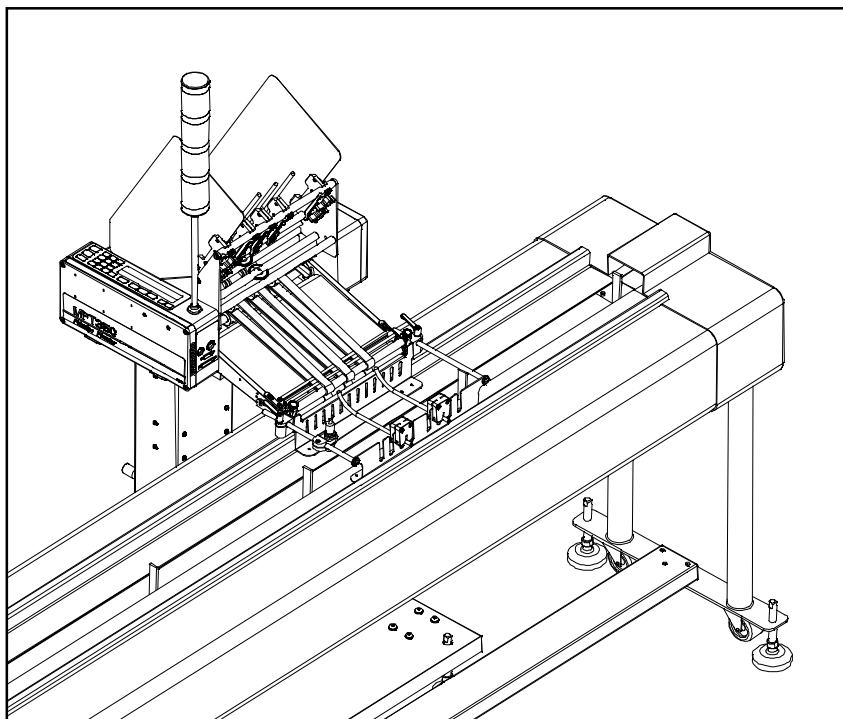

Fig. 2. The SMCT style Catch Tray in use with the HSC-3 High Speed Collator

**Multifeeder**<sup>®</sup>  
TECHNOLOGY

Multifeeder Technology®, Inc.  
4821 White Bear Parkway  
St. Paul, MN 55110

Phone: 651-407-3100  
Fax: 651-407-3199

E-mail: [info@multifeeder.com](mailto:info@multifeeder.com)  
Website: [www.multifeeder.com](http://www.multifeeder.com)