

Multifeeder Technology®

MFT350™

Series of Friction Feeders

*The Leader in High Performance,
High Speed Friction Feeding
Equipment and Accessories*

MFT 350™ Typical Applications

- Pharmaceutical Inserts
- Blister Packs
- Compact Discs
- Coupons
- Booklets
- Stickers
- Z-Folds
- Greeting Cards
- Labels
- Inserts
- Credit Cards
- Pouches/Bags
- Tipping
- Magnets
- And many more...

Multifeeder®
TECHNOLOGY

A Hardworking, Multifunctional Friction Feeder

For all of your feeding needs, Multifeeder Technology® has a solution for you. The MFT series of friction feeders is designed to handle a wide variety of products, with minimal changeover and set up. Whether you are individually feeding compact discs or batch counting 100 sheets of paper, we have a system to meet your specific requirements.

All Multifeeder Technology friction feeders include double detection, mis-feed detection and batch counting as standard features, rather than costly extras. With an MFT friction feeder, everything you need is right at your fingertips.

Maximize Productivity

A few minor adjustments allow you to make product changeovers in minutes, saving you valuable time and resources. The specially-designed sealed membrane keypad contains easy access “Hot Keys” for the most frequently used control adjustments. Standard features like these make Multifeeder Technology friction feeders extremely user friendly and help maximize your uptime.

Superior Technology

All MFT friction feeders are powered by a high speed, brushless servo motor with encoder feedback, while infrared sensors are used to visually inspect your product

as it's being fed. An on-board computer monitors and controls the entire process, providing accurate speed, product count, feeding jam/empty control and multiple product detection.

Our innovative patented feeding mechanism ensures your product's integrity remains intact by gently separating product from the bottom of an inclined stack, regardless of the material consistency or thickness.

If you're looking for a simple solution to feeding products quickly, reliably and accurately, call Multifeeder Technology today.



MFT350™ Series of Friction Feeders

The Leader in High Performance, High Speed Friction Feeding Equipment and Accessories

MFT 350™ Standard Features

- Portable Unit:** Self-contained unit with one electrical motor and enclosure
- Computer Controlled:** Computer control provides thousands of control calculations per second for precise start, stop, watch dog and multiple product detection
- Easy Interface:** Standard signals available for easy interface with existing computer, PLC or other host machinery
- Production Log:** Automatically stores your production history in the feeder's computer with production counts
- Intuitive User Interface:** Custom 22-key sealed membrane key pad with 2 x 40 character LCD display
- User Friendly Changeover:** Easy and accurate changeover with twist lock handles
- Ruggedly Built:** Hardened stainless steel shafts and sealed bearings for maximum life and 24/7 operation
- Quick Belt Replacement:** Three piece shaft assemblies for quick maintenance
- Three-Color Signal Light:** Green = ready Yellow = low product Red = stop
- Pre-select Counter:** Standard pre-select product count (1-9999 per cycle)
- Optically Isolated Signals:** All interface signals isolated for accuracy
- Built for Harsh Environment:** Stainless steel shafts, sealed bearings, surface treated aluminum construction and sealed aluminum enclosures to protect internal parts
- One Year Warranty:** One year warranty on parts and labor

MFT 350™ Specifications

- Minimum Product Size:** 25mm(W) x 25mm(L) [1" x 1"]
- Maximum Product Size:** 300mm(W) x 400mm(L) [12" x 16"]
- Minimum Product Thickness:** 0.05mm [0.002"]
- Maximum Product Thickness:** 30mm [1.18"]
- Maximum Belt Speed:** 211,000 mm/min [8300 in/min]
- Operating Temperature:** 10-35° C [50-90° F]
- Power Requirements:** 110 volts 50-60 HZ maximum 6 amps
- Total Unit Weight:** 32 kg [70 lbs]
- Product Magazine:** 432mm [17"] or 686 mm [27"]
- Feeder Discharge:** Five standard lengths – others available
- Production Log**

We configure your machine for maximum performance. Other sizes available.

MFT 350™ Options

- Automatic Product Loader
- Automatic Drop Table
- Remote Key Pad
- Static Control
- Tall Product Magazines
- Collators
- Systems
- Portable Stand on casters
- Catch Tray – side or end load
- Barcode Scanner
- Inkjet Printer
- Transformer
- Print and Apply
- Production Logo Printer

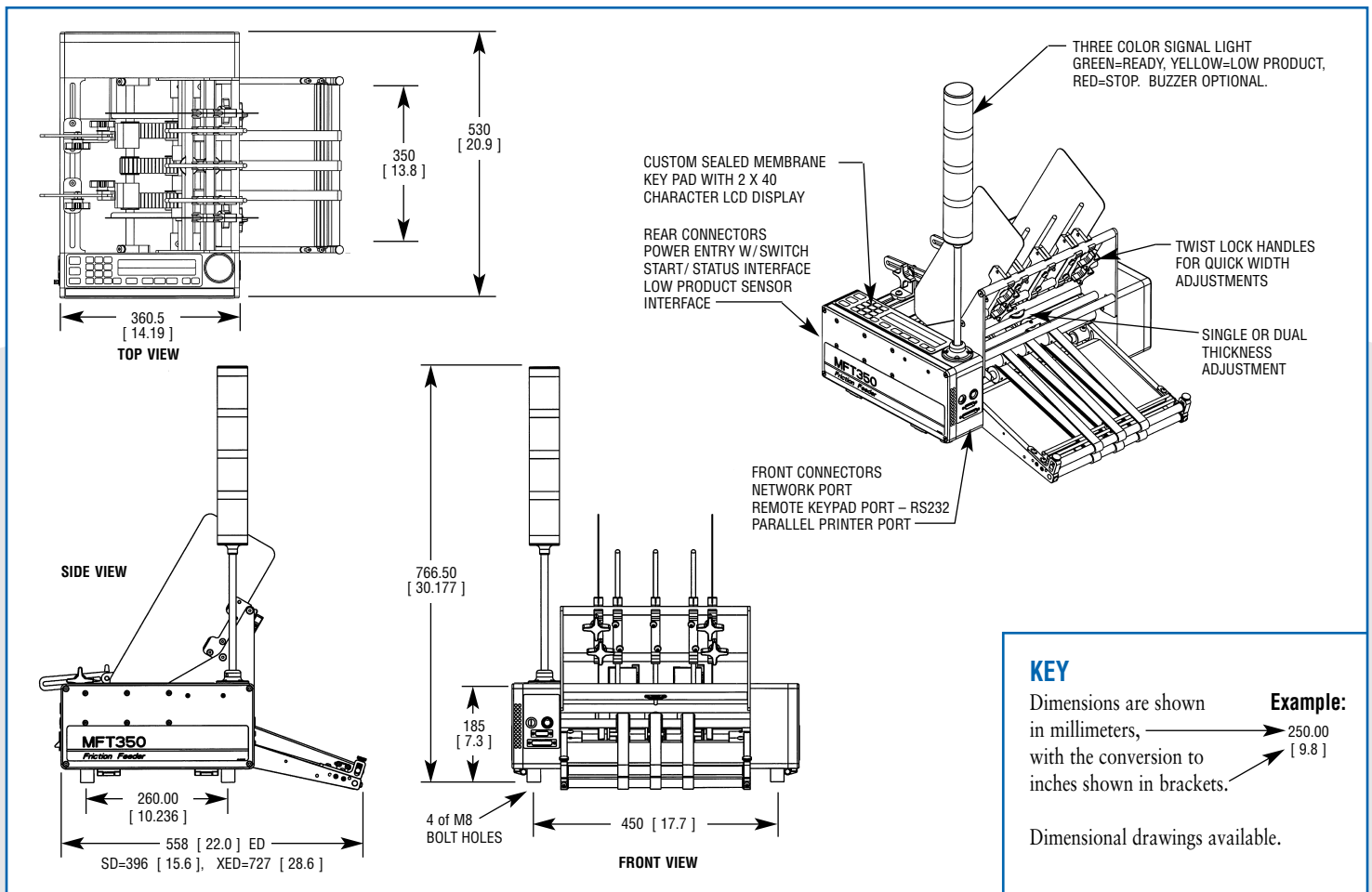

Multifeeder Technology,® Inc.
4821 White Bear Parkway
St. Paul, MN 55110

Phone: 651-407-3100
Fax: 651-407-3199

E-mail: info@multifeeder.com
Website: www.multifeeder.com